

PIASTRA ANGOLARE EV CC41-1 HCP

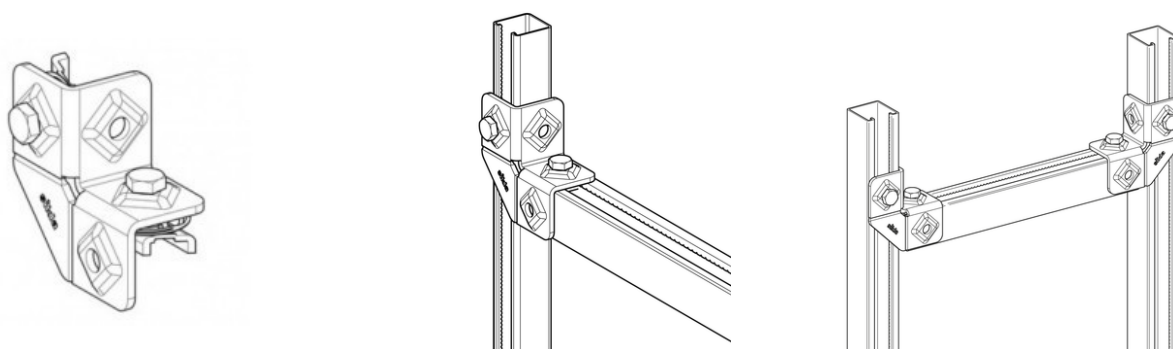

APPLICATION

Pre-assembled connecting element for frame structures made of channels.

High-speed assembly system for 90° structures of Channels MS 41.

Locks automatically by pushing down the bolt head and at the same time supports its own weight. Secure, form-locking, non-positive connection. Serrated speed nut with

clamping bolt M10. Ideal shaping and high-strength material for high stiffness.

Flexible direction of the channel opening.

SCOPE OF DELIVERY

With Speed Nut and Hexagon Bolt SKT (supplied loose).

INSTALLATION

To be used in pairs.

PROSYSTEM ITALIA SRL

Via Friuli venezia Giulia, 15
30030 Pianiga - Venezia - Italy
T +39.041.510.1622
F +39.041.5131351

P.IVA 03470750278
Reg.Imp. Ve 03470750278
Cap.soc. € 90.000,00
REA Padova n° 311219

info@prosystemitalia.com
prosystemitalia.com

TECHNICAL DATA

Max. perm. working load: 5.0 kN centre load per crossbar fixed with 2 Angle Connectors EV CC 41-1

Tightening torque: 40 Nm

Material: Steel, electro-galvanised

Codice	Nome	Peso	Numero di pezzi
117352	EV CC41-1 HCP	0.38	25

PROSYSTEM ITALIA SRL

Via Friuli venezia Giulia, 15
30030 Pianiga - Venezia - Italy
T +39.041.510.1622
F +39.041.5131351

P.IVA 03470750278
Reg.Imp. Ve 03470750278
Cap.soc. € 90.000,00
REA Padova n° 311219

info@prosystemitalia.com
prosystemitalia.com