

# U-HOLDER SB F 100

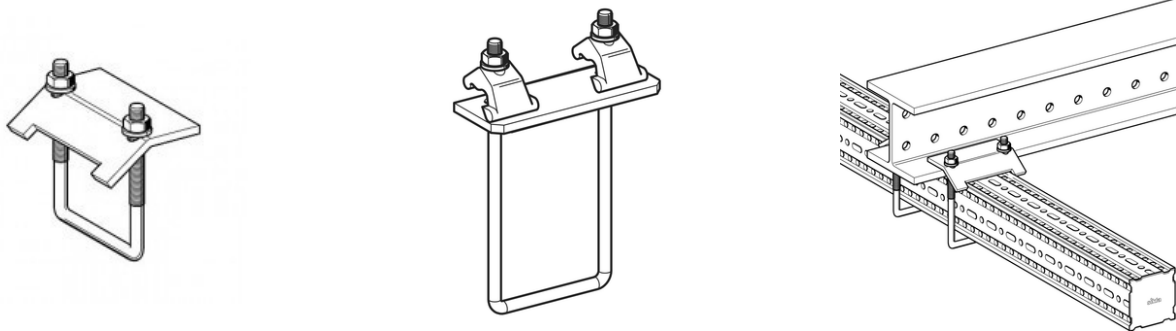

## APPLICATION

Pre-assembled component to clamp Beam Section F100 to the flange side of traditional steel sections.

## SCOPE OF DELIVERY

Type SB F 100-16:

- Holder with thread M10;
- Plate;
- 2 Hexagon nuts M10;
- 2 Washers.

Type SB F 100-40 and 100/160-40:

- Holder with thread M12;
- Plate;
- 2 Beam Clips SPA 5P AU;
- 2 Hexagon nuts M12.

### PROSYSTEM ITALIA SRL

Via Friuli venezia Giulia, 15  
30030 Pianiga - Venezia - Italy  
T +39.041.510.1622  
F +39.041.5131351

P.IVA 03470750278  
Reg.Imp. Ve 03470750278  
Cap.soc. € 90.000,00  
REA Padova n° 311219

[info@prosystemitalia.com](mailto:info@prosystemitalia.com)  
[prosystemitalia.com](http://prosystemitalia.com)

## INSTALLATION

U-Holder to be used in pairs.

Type 16 up to flange thickness 16 mm

Type 40 up to flange thickness 40 mm

## TECHNICAL DATA

Material: Steel, HCP.

Type	Thread	Tightening torque[Nm]	Max. Fz force [kN]
SB F 100-16	M10	40	9.5
SB F 100-40	M12	85	16
SB F 100/160-40	M12	85	16

Codice	Nome	Peso	Numero di pezzi
113082	SB F 100/16 mm	0.68	20
113083	SB F 100/40 mm	1.65	10
113101	SB F 100/160-40 mm	1.73	10

### PROSYSTEM ITALIA SRL

Via Friuli venezia Giulia, 15  
30030 Pianiga - Venezia - Italy  
T +39.041.510.1622  
F +39.041.5131351

P.IVA 03470750278  
Reg.Imp. Ve 03470750278  
Cap.soc. € 90.000,00  
REA Padova n° 311219

[info@prosystemitalia.com](mailto:info@prosystemitalia.com)  
[prosystemitalia.com](http://prosystemitalia.com)