

# BEAM BRACKET TKO F 80

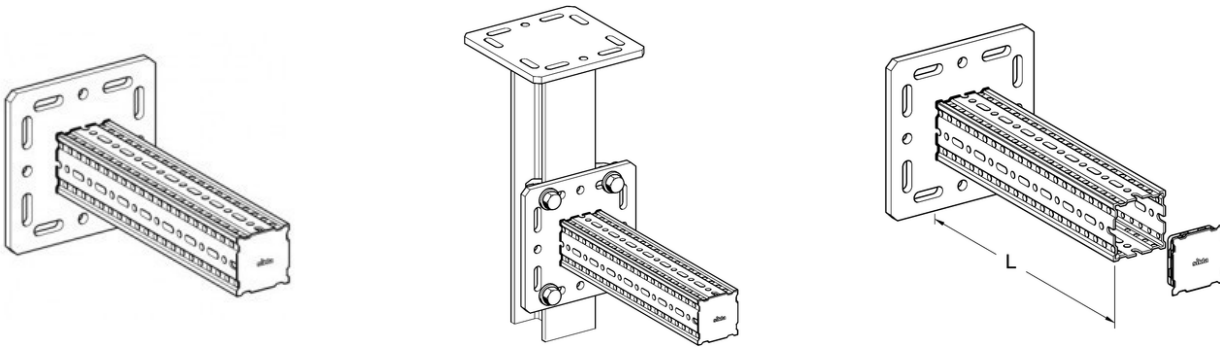

## APPLICATION

Galvanised hollow-box-section with welded end-plate to serve as cantilever arm. May be used as a crossbar when combined with End Support STA/End Support WBD and 4 x Self Forming Screw FLS .

## SCOPE OF DELIVERY

With pre-assembled End Cap ADK F 80.

## INSTALLATION

Depending on the situation, different options are recommended:

- a) Directly to building structure: 4 x suitable wall anchors
- b) To traditional steel beams between 80 – 120 mm flange dimensions: 1x Assembly Set 5P M12 S
- c) To traditional steel beams > 120 flange dimension: with on-demand Adaptor Plate (tbc)
- d) To Steel Beams 100/120: with Bracket Plates FV 100/120 when positive mechanical connection required

### PROSYSTEM ITALIA SRL

Via Friuli venezia Giulia, 15  
30030 Pianiga - Venezia - Italy  
T +39.041.510.1622  
F +39.041.5131351

P.IVA 03470750278  
Reg.Imp. Ve 03470750278  
Cap.soc. € 90.000,00  
REA Padova n° 311219

[info@prosystemitalia.com](mailto:info@prosystemitalia.com)  
[prosystemitalia.com](http://prosystemitalia.com)

## TECHNICAL DATA

Type	L[mm]	Dimensions of base plate[mm]	Slots in base plate for
TKO F80-400	400	220 x 220 x 12	M12
TKO F80-800	800	220 x 220 x 12	M12

Configuration: Base plate welded to Beam Section TP F 80.

Material:

- Base plate: Steel, HCP;
- Beam section: Steel, HCP.

## APPROVALS

CE mark, according to EN 1090; MPA tested.



Codice	Nome	Peso	Numero di pezzi
192788	TKO F 80 L=400mm	6.6	1
192795	TKO F 80 L=800mm	9.2	1

### PROSYSTEM ITALIA SRL

Via Friuli venezia Giulia, 15  
30030 Pianiga - Venezia - Italy  
T +39.041.510.1622  
F +39.041.5131351

P.IVA 03470750278  
Reg.Imp. Ve 03470750278  
Cap.soc. € 90.000,00  
REA Padova n° 311219

[info@prosystemitalia.com](mailto:info@prosystemitalia.com)  
[prosystemitalia.com](http://prosystemitalia.com)