

FIXED POINT SET XS

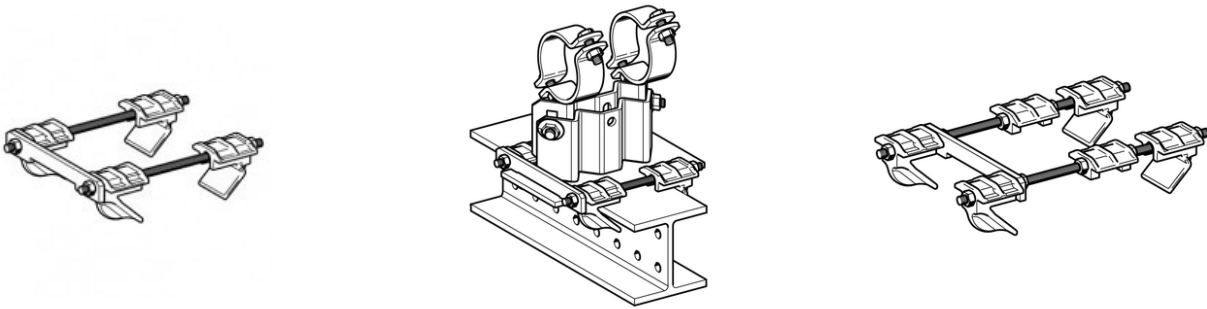

APPLICATION

Modification of Sliding Pipe Shoes to Fixed Point Pipe Shoes. The slide plate has to be removed.

Max. beam flange width $t \leq 30$ mm

SCOPE OF DELIVERY

Pre-assembled Fixed Point Set containing:

- 4 Clamping hooks;
- 2 Grub screws;
- 1 Cross bar;
- 2 Lift-off preventions (XS 280/300);
- Hexagon nuts:
 - 4 for XS 80/120 and XS 140/160 each;
 - 6 for XS 180/220 and XS 240/260 each;
 - 10 for XS 280/300.

PROSYSTEM ITALIA SRL

Via Friuli venezia Giulia, 15
30030 Pianiga - Venezia - Italy
T +39.041.510.1622
F +39.041.5131351

P.IVA 03470750278
Reg.Imp. Ve 03470750278
Cap.soc. € 90.000,00
REA Padova n° 311219

info@prosystemitalia.com
prosystemitalia.com

TECHNICAL DATA

Material:

- Material parts: Steel, HCP;
- Grub screws, nuts: Steel, HCP;
- Clamping hooks: Cast iron, HCP.

Type	For flange width [mm]
XS 80/120	80 - 120
XS 140/160	140 - 160
XS 180/220	180 - 220
XS 240/260	240 - 260
XS 280/300	280 - 300

APPROVALS

Certification of quality TUV-Rheinland nr.102793.



Codice	Nome	Peso	Numero di pezzi
110357	XS 80/120	2.25	-
110358	XS 140/160	2.4	-
110359	XS 180/220	2.5	-

PROSYSTEM ITALIA SRL

Via Friuli venezia Giulia, 15
30030 Pianiga - Venezia - Italy
T +39.041.510.1622
F +39.041.5131351

P.IVA 03470750278
Reg.Imp. Ve 03470750278
Cap.soc. € 90.000,00
REA Padova n° 311219

info@prosystemitalia.com
prosystemitalia.com

Codice	Nome	Peso	Numero di pezzi
110360	XS 240/260	2.6	-
110361	XS 280/300	3.2	-

PROSYSTEM ITALIA SRL

Via Friuli venezia Giulia, 15
30030 Pianiga - Venezia - Italy
T +39.041.510.1622
F +39.041.5131351

P.IVA 03470750278
Reg.Imp. Ve 03470750278
Cap.soc. € 90.000,00
REA Padova n° 311219

info@prosystemitalia.com
prosystemitalia.com