

WELDING ADAPTER ASA F 100 GPL 8 KT

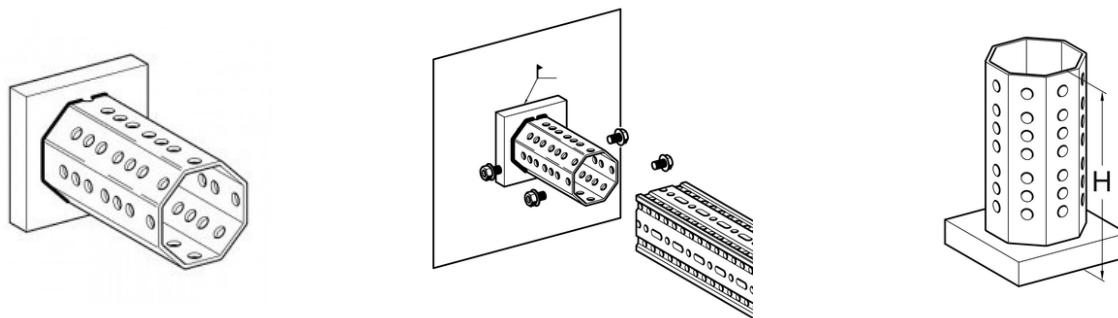

APPLICATION

Welding plate with octagonal insert to receive siFramo section. May be implemented into the structural steel design in anticipation of siFramo-frames or used in situ as a connection element when clamping is not an option but hot works are permitted. The octagonal insert allows for full utilisation of beam section within the space required by the Welding Adapter ASA itself.

SCOPE OF DELIVERY

Mounting Plate 100 with welded on octagonal joint.

INSTALLATION

The welding plate of the ASA can be welded directly without previous treatment due to a corrosion-resistant weld-thru coating which is compatible with both the HDG surface of the siFramo section and the health and safety requirements of the welding process. Once the ASA adapter has been connected, the coating may also receive paint without previous treatment. The siFramo section must be connected to the Welding Adapter ASA with 4 x Self Forming Screw FLS.

PROSYSTEM ITALIA SRL

Via Friuli venezia Giulia, 15
30030 Pianiga - Venezia - Italy
T +39.041.510.1622
F +39.041.5131351

P.IVA 03470750278
Reg.Imp. Ve 03470750278
Cap.soc. € 90.000,00
REA Padova n° 311219

info@prosystemitalia.com
prosystemitalia.com

TECHNICAL DATA

Type	Adapter sizeH [mm]	Mounting Plate size[mm]
ASA F 100 GPL 8kt	200	120 x 120 x 20

Material: Steel, HCP.

APPROVALS

Ce mark, according to EN 1090.



Codice	Nome	Peso	Numero di pezzi
113080	ASA F 100 GPL	3.3	1

PROSYSTEM ITALIA SRL

Via Friuli venezia Giulia, 15
30030 Pianiga - Venezia - Italy
T +39.041.510.1622
F +39.041.5131351

P.IVA 03470750278
Reg.Imp. Ve 03470750278
Cap.soc. € 90.000,00
REA Padova n° 311219

info@prosystemitalia.com
prosystemitalia.com