

BEAM CLAMP TCS 41

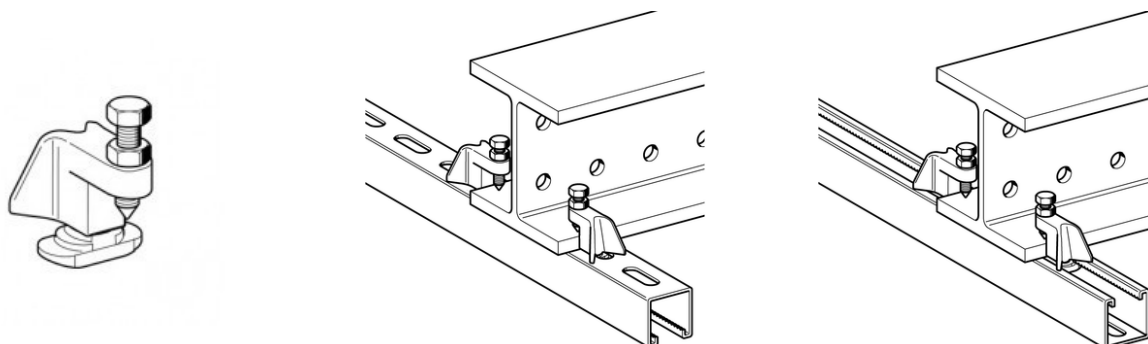

APPLICATION

The new Beam Clamp 41 allows for a direct connection of 41mm slotted strut channel to beam without having this obstruction. In order to achieve this, the foot of the Beam Clamp must be inserted into the slot on the back of the channel.

SCOPE OF DELIVERY

Cast iron part, completely pre-assembled with clamping bolt and locking nut.

INSTALLATION

Insert the foot of the Beam Clamp into the slot on the back of the channel, twist by 90° and push it against the beam's flange. First tighten bolt of Beam Clamp (hand-tight), then tighten further with 1 1/2 turns. The sharpened tip of the bolt will dent the beam thus providing a high level of safety. At last tighten locking nut. Every channel (statically determined) has to be fixed at least twice.

TECHNICAL DATA

PROSYSTEM ITALIA SRL

Via Friuli venezia Giulia, 15
30030 Pianiga - Venezia - Italy
T +39.041.510.1622
F +39.041.5131351

P.IVA 03470750278
Reg.Imp. Ve 03470750278
Cap.soc. € 90.000,00
REA Padova n° 311219

info@prosystemitalia.com
prosystemitalia.com

The following nominal load applies for a new Beam Clamp fixed to an undamaged beam flange.

Nominal load: 4.0 kN

Clamping range on parallel flange: 20 mm

Material: Cast iron, clamping bolt 8.8, electro galvanised.

Codice	Nome	Peso	Numero di pezzi
110004	TCS 41	0.12	-

PROSYSTEM ITALIA SRL

Via Friuli venezia Giulia, 15
30030 Pianiga - Venezia - Italy
T +39.041.510.1622
F +39.041.5131351

P.IVA 03470750278
Reg.Imp. Ve 03470750278
Cap.soc. € 90.000,00
REA Padova n° 311219

info@prosystemitalia.com
prosystemitalia.com