

PIVOT JOINT GE F 100

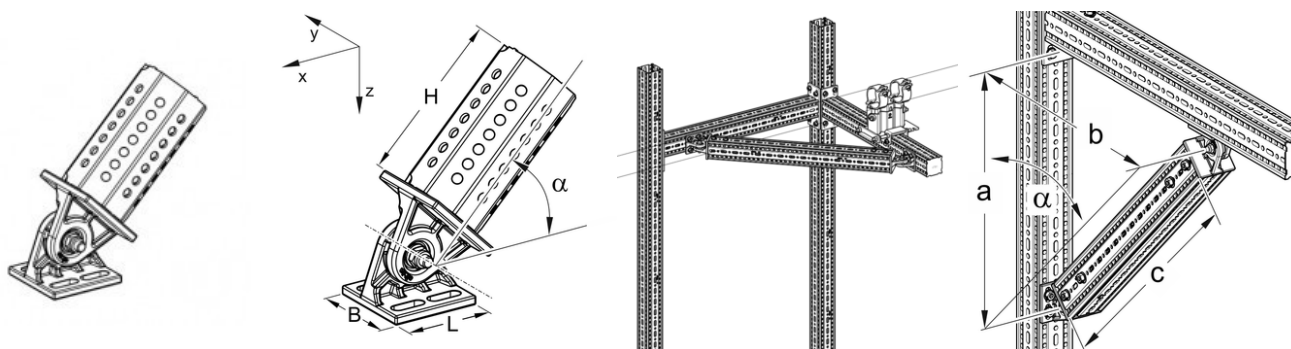

APPLICATION

Applicable as a bracing element for single-arm cantilevers in conjunction with siFramo 100 section, and for the knee-brace reinforcing of siFramo frame constructions. The pivot can be installed with angles from 25° to 155°.

INSTALLATION

Attachment of the Joints to Beam Section TP F 100 by means of 4 Self Forming Screws FLS F at the base plate. The support profile TP F 80 or TP F 100 (depending on joint type) plugged onto the octagon is also attached by means of 4 Self Forming Screws, so 8 Self Forming Screws are necessary in total. The cutting length of the support profile can be determined by the table below-mentioned. After installation at the desired angle the screws have to be tightened with 40 Nm.

TECHNICAL DATA

Material: Steel, HCP.

Type	Height H[mm]	Length L[mm]	Width B[mm]	Angle α
GE F 100 - 80	140	100	100	25° - 155°
GE F 100 - 100	180	100	100	25° - 155°

PROSYSTEM ITALIA SRL

Via Friuli venezia Giulia, 15
30030 Pianiga - Venezia - Italy
T +39.041.510.1622
F +39.041.5131351

P.IVA 03470750278
Reg.Imp. Ve 03470750278
Cap.soc. € 90.000,00
REA Padova n° 311219

info@prosystemitalia.com
prosystemitalia.com

Cutting length c of support profile between two joints:

	b [mm]1000	b [mm]1500	b [mm]2000	b [mm]2500	b [mm]3000
α	c [mm]	c [mm]	c [mm]	c [mm]	c [mm]
25°	2155	3340	4525	5710	6890
30°	1810	2810	3810	4810	5810
35°	1565	2435	3305	4180	5050
40°	1380	2160	2940	3720	4495
45°	1245	1955	2660	3370	4075
50°	1145	1800	2450	3100	3755
55°	1060	1670	2285	2895	3505
60°	1000	1580	2155	2730	3310
65°	950	1500	2055	2605	3155

a = vertical length from centerline of joint to bottom of profile at connection
 b = horizontal length of cantilever from connection to centerline of joint
 c = cutting length of support profile between two joints
 α = angle at the opposite of the vertical bracing

Codice	Nome	Peso	Numero di pezzi
113838		2.3	1
113837		3	1

PROSYSTEM ITALIA SRL

Via Friuli venezia Giulia, 15
 30030 Pianiga - Venezia - Italy
 T +39.041.510.1622
 F +39.041.5131351

P.IVA 03470750278
 Reg.Imp. Ve 03470750278
 Cap.soc. € 90.000,00
 REA Padova n° 311219

info@prosystemitalia.com
prosystemitalia.com