

PROVENT

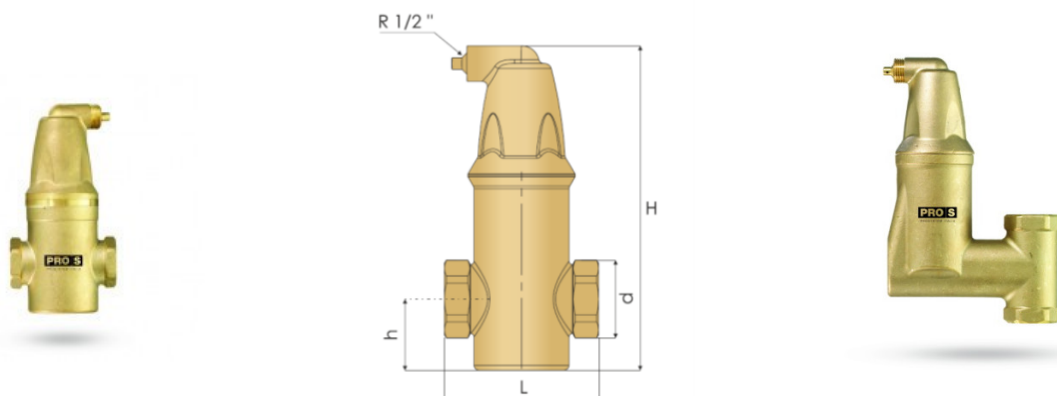

APPLICATION

Provent in-line deaerators are suitable for closed-circuit heating or cooling systems. They expel air, microbubbles and other gases from the system, quickly, automatically and reliably.

Equipped with a special MicroSmart Screen stainless steel mesh.

PROvent must be installed with the pipe in a horizontal position.

Technical Data	Provent
Body:	Brass
Connections:	threaded 1"-2"
Max. operating temperature:	110 ° C
Max. operating pressure:	10 bar

Model	Position	H [mm]	h [mm]	L [mm]
3/4"	orizz.			
1"	orizz.	162	40	85

PROSYSTEM ITALIA SRL

Via Friuli venezia Giulia, 15
30030 Pianiga - Venezia - Italy
T +39.041.510.1622
F +39.041.5131351

P.IVA 03470750278
Reg.Imp. Ve 03470750278
Cap.soc. € 90.000,00
REA Padova n° 311219

info@prosystemitalia.com
prosystemitalia.com

1"¼	orizz.	164	41	88
1"½	orizz.	188	45	99
2"	orizz.	188	46	99
1"	vert.	210	86	137

Codice	Nome	Peso	Numero di pezzi
32460	Provent 3/4"	1.38	6
32461	Provent 1"	1.7	1
32462	Provent 1 1/4"	1.7	1
32463	Provent 1 ½"	1.7	1
32464	Provent 2"	1.7	1
32466	Provent 1"	3.3	1

PROSYSTEM ITALIA SRL

Via Friuli venezia Giulia, 15
30030 Pianiga - Venezia - Italy
T +39.041.510.1622
F +39.041.5131351

P.IVA 03470750278
Reg.Imp. Ve 03470750278
Cap.soc. € 90.000,00
REA Padova n° 311219

info@prosystemitalia.com
prosystemitalia.com